

A D I R O N D A C K ▲ A I R E

Cold Point Corporation, Rome, New York 13440 Phone (315)339-2331 Fax (315)339-2358 Web: www.COLDPOINTCORP.com



PTAC Replacement Chassis Installation Operation and Maintenance



MADE IN
USA 

Thank you for choosing Adirondack Aire products! We have designed and manufactured this unit to be safe and trouble free. As the installer of this unit, you play a major role in assuring it's intended performance and customer satisfaction. The important information provided here will help you install the unit correctly, eliminate callbacks, and assure optimal performance and service life. If you are in need of technical or warranty assistance contact us by phone, mail, Fax, or e-mail:

Cold Point Corp.
7500 Cold Point Drive
Rome, NY 13440
Phone: 315.339.2331
Fax: 315.339.2358
WEB: www.coldpointcorp.com or
www.adirondackaire.com
e-mail: info@coldpointcorp.com

When calling for assistance please have the following information ready:

- Model Number
- Serial Number
- Date of Installation

REPLACEMENT 'EK' CHASSIS PRODUCT DESCRIPTION:

Note: This instruction provides installation, operating, and maintenance instructions for the 'EK' cooling chassis. Refer to separate instructions for optional room cabinet, control box, and blower/ heat section installation.

These instructions apply to a new *Adirondack-Aire* chassis designed to replace an existing *Singer/McQuay/ Reminton EK Packaged Terminal Air Conditioner*, (PTAC). The chassis is a part of a complete system, which consists of the chassis, wall sleeve, outdoor louver, room cabinet, evaporator blower assembly and control box. With an electric or hydronic heat section. The chassis contains the compressor, indoor and outdoor heat exchangers, vent damper (optional), condenser fan/motor assembly, and controls. The *Adirondack-Aire* replacement chassis fits the existing wall sleeves and room cabinets without modification. Using Adirondack-Aire replacements eliminates the need for room and exterior wall renovation and is the solution that the property back in service quickly and at the lowest total cost.

GENERAL:

These instructions give information relative to Adirondack-Aire replacement PTAC chassis for use in existing wall sleeves and room cabinets (See FIG. 1). This manual is intended as an aid to qualified service personnel for proper installation, operation, and maintenance of the new chassis. Read these instructions thoroughly before proceeding with the installation. **Take note of special safety and performance cautions highlighted throughout these instructions.** **HIGHLIGHT** is used to highlight important information throughout these instructions. Local codes, if different from these instructions, must be followed and supplement or supersede these instructions.

Retain this manual for future reference. A copy should be left on premises with the maintenance and/or administrative department at the property.

FIG. 1

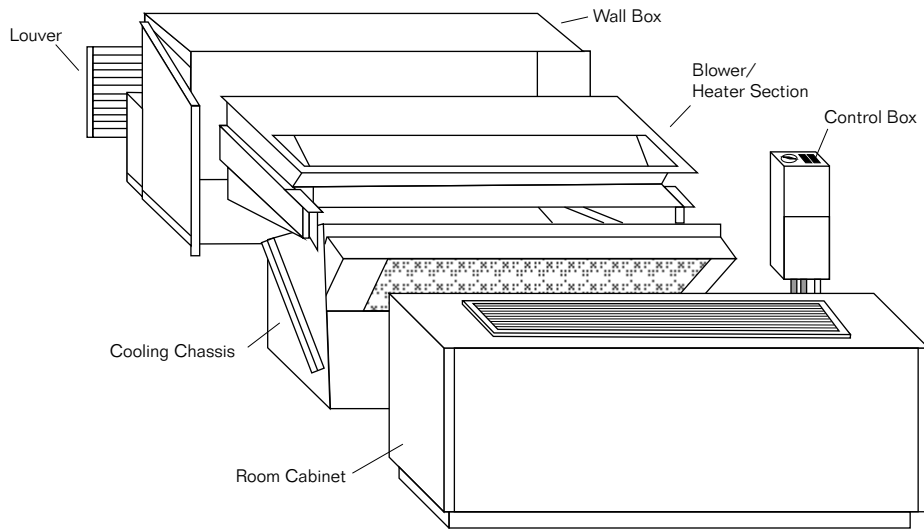

PRE-INSTALLATION SAFETY INSTRUCTIONS:

FAILURE TO FOLLOW THESE INSTRUCTIONS CAN RESULT IN FIRE OR ELECTRICAL SHOCK CAUSING SERIOUS PERSONAL INJURY OR DEATH AND PROPERTY DAMAGE.

- READ ALL INSTRUCTIONS CAREFULLY BEFORE PROCEEDING WITH THE INSTALLATION. KEEP THIS MANUAL FOR FUTURE REFERENCE.
- INSTALL OR LOCATE THE UNIT ONLY IN ACCORDANCE WITH THESE INSTRUCTIONS.
- USE THIS UNIT ONLY FOR ITS INTENDED PURPOSE AS DESCRIBED IN THIS MANUAL.
- CHECK THE RATING PLATE ON THE NEW UNIT BEFORE INSTALLATION TO MAKE CERTAIN THE UNIT VOLTAGE IS THE SAME AS THE ELECTRICAL SUPPLY. DO NOT PROCEED IF THERE IS A DISCREPANCY.
- THE UNIT MUST BE CONNECTED TO A PROPERLY GROUNDED ELECTRICAL SUPPLY. FAILURE TO DO SO WILL CAUSE A SERIOUS SAFETY HAZARD!
- THE USE OF EXTENSION CORDS IS PROHIBITED.
- ELECTRICAL SUPPLY MUST HAVE OVERLOAD FUSE/BREAKER PROTECTION AS STATED ON UNIT RATING PLATE.
- TURN OFF THE ELECTRICAL SUPPLY BEFORE BEGINNING THE INSTALLATION OR BEFORE SERVICE PANELS ARE REMOVED!
- STOP THE INSTALLATION IF UNIT HAS DAMAGED WIRING, IS NOT WORKING PROPERLY, OR HAS BEEN DAMAGED OR DROPPED.

IMPORTANT ALTERATIONS AND REPLACEMENT PARTS:

ALTERING THE PRODUCT OR REPLACING PARTS WITH NON AUTHORIZED FACTORY PARTS WILL VOID THE FACTORY WARRANTY AND MAY RESULT IN ADVERSE OPERATIONAL PERFORMANCE AND / OR A POSSIBLE HAZARDOUS SAFETY CONDITION TO SERVICE PERSONNEL AND OCCUPANTS. IF YOU ARE IN DOUBT AS TO HOW TO SERVICE THIS UNIT OR WHERE TO FIND FACTORY REPLACEMENT PARTS, CALL COLD POINT CORP. @ 315.339.2331 FOR ASSISTANCE.

UNPACKING AND INSPECTION:

The *Adirondack-Aire* replacement PTAC chassis is shipped completely assembled and ready to install. All goods are inspected at the factory and released to the freight company in good condition. When received at the site, a visual inspection of all packages should be made immediately. Carefully check the shipment against the bill-of-lading. Any evidence of rough handling or apparent damage should be noted on the delivery receipt and the material inspected in the presence of the carrier's representative. If damage is found a claim should be filed with the freight company within (15) days. IT IS THE RESPONSIBILITY OF THE PURCHASER TO FILE ALL CLAIMS WITH THE FREIGHT COMPANY.

STORAGE:

These units are intended for in-wall use only. **Store all chassis upright. Failure to do so may cause damage to the internal components resulting in safety and/or performance problems!** To protect the unit from damage due to the elements and prevent it from possibly becoming a source of IAQ problems, the unit should be stored indoors. If indoor storage is not possible, the following provisions must be met:

1. Place the unit on a dry surface or raise off the ground to assure adequate air circulation beneath the unit and to assure that no

portion of the unit contact standing water at any time.

2. Cover the unit with a water repellant tarp to protect it from the elements
3. Make provisions for continuous venting of the covered unit to prevent moisture build-up from accumulating on the unit surfaces.

IMPORTANT INSTALLATION CONSIDERATIONS:
THE INSTALLATION **MUST** COMPLY WITH ALL OF THE FOLLOWING CONSIDERATIONS. ANY DEFICIENCIES MUST BE CORRECTED BEFORE COMPLETING THE INSTALLATION! FAILURE TO COMPLY WILL CREATE UNSAFE AND/OR PERFORMANCE AND SERVICE LIFE PROBLEMS AND WILL VOID THE PRODUCT WARRANTY.

- THE CHASSIS IS TO BE USED ONLY WITH METAL WALL SLEEVES AND ROOM CABINETS.
- THE ROOM CABINET MUST INCLUDE A FRONT PANEL SECURED WITH SCREWS THAT PREVENTS CONTACT WITH CHASSIS PARTS (EXCEPT OPERATING CONTROLS).
- ALL WIRING MUST COMPLY WITH 'NEC' AND LOCAL CODES.
- 265 VOLT UNITS MUST EMPLOY RECEPTACLES LOCATED WITHIN THE CABINET OR SUBBASE.
- THE SUPPLY AIR GRILLE MUST HAVE MINOR DIMENSION SPACING NO LARGER THAN ½". FOR ADEQUATE AIRFLOW THE GRILLE MUST HAVE AT LEAST 200 SQUARE INCHES OF AIR OUTLET AREA.
- THE TOP SURFACE OF THE CABINET MUST BE AT LEAST 1" FROM THE CHASSIS AIR OUTLET SURFACE. OUTLET AIR MUST NOT BE BLOCKED BY FURNITURE, CURTAINS, OR OTHER OBSTRUCTIONS THAT BLOCK AIRFLOW OR CAUSE AIR RECIRCULATION.
- CARPET, FURNITURE, OR OTHER OBSTRUCTIONS THAT WILL HINDER FREE AIRFLOW TO THE UNIT MUST NOT BLOCK THE RETURN AIR.
- OPENINGS IN OUTDOOR EXPOSURE LOUVERS OR GRILLES MUST HAVE MINOR DIMENSION OPENINGS NO LARGER THAN 1" TO PREVENT CONTACT WITH MOVING PARTS. AIRFLOW MUST NOT BE OBSTRUCTED BY DAMAGED, CLOGGED, OR MISALIGNED LOUVERS. INSTALLATIONS WHERE NON-STANDARD LOUVERS ARE EMPLOYED MUST BE APPROVED

- BY THE FACTORY IN ADVANCE OF REPLACEMENT CHASSIS INSTALLATION.
- THE CHASSIS CONDENSER COIL MUST ALIGN WITH AND CONTACT THE OUTDOOR LOUVER. IF BAFFLES ARE EMPLOYED THEY MUST BE OF PROPER DESIGN, SIZE, AND LOCATION TO PREVENT AIR RECIRCULATION! FAILURE TO DO SO WILL DEGRADE OR INHIBIT UNIT PERFORMANCE AND SERVICE LIFE. WARRANTY WILL BE VOIDED IF AIR RECIRCULATION IS PRESENT.
- SHRUBS, PLANTS, FENCES, OR STRUCTURES MUST NOT OBSTRUCT OUTDOOR AIRFLOW. BUILDING MODIFICATIONS OR STRUCTURES MUST NOT BLOCK OR OBSTRUCT FREE AIRFLOW TO THE OUTDOOR SECTION OF THE UNIT. UNITS MUST NOT BE POSITIONED SUCH THAT THE DISCHARGE AIR OF ONE UNIT BLOWS TO THE INLET OF AN ADJACENT UNIT.
- OUTDOOR AIR INFILTRATION AROUND THE WALL SLEEVE AND CHASSIS MUST BE SEALED. FAILURE TO DO SO WILL OVERLOAD THE ROOM AND MAY RESULT IN COMFORT AND ENERGY COST PROBLEMS. IN COLD CLIMATES COLD AIR ENTERING AROUND THE UNIT CAN FREEZE AND BURST HOT WATER OR STEAM HEAT COILS CAUSING SERIOUS DAMAGE TO THE BUILDING AND CONTENTS!

INSTALLATION:

Work with a helper to avoid personal injury or property damage if the chassis is too heavy or awkward to handle alone. If necessary, provide a drop cloth or other floor protection as removal of the chassis may drop out dirt and/or water as removal proceeds.

REMOVAL OF THE OLD CHASSIS:

- 1). Disconnect the power supply by turning off the power at the circuit breaker panel. **Be sure to tag or lock the breaker to prevent accidental or inadvertent re-energizing of the circuit.**
- 2). Remove the room cabinet front panel to expose the old chassis.
- 3). Locate the electrical plug that runs from the control box to the bottom right side of the chassis and unplug it from the chassis.
- 4). Remove the chassis by sliding it into the room. Be careful not to pinch or damage wiring, heat coils, and/or piping as the chassis is slid from the sleeve/cabinet.
- 5). **IMPORTANT** Dispose of the old chassis in accordance with state and federal regulations! It is illegal to discharge

refrigerant into the atmosphere. Use proper reclaiming methods if the refrigerant circuit seal is broken.

PREPARE FOR INSTALLATION OF THE NEW CHASSIS:

Note: If new room cabinet, control section, and/or heat sections are to be installed they must be installed first before proceeding with the chassis installation.

- 1). **IMPORTANT** Inspect the wall sleeve for rust, holes, or damage. Clean and repair or replace as necessary.
- 2). Check wall sleeve level. Note that the bottom is pitched to the outside to assure drainage of rain and/or condensate water. Clear drain slots or holes of dirt and/or obstructions. Correct level and re-secure as necessary.
- 3). Inspect the wall sleeve-to-wall seal and reseal as necessary using high quality insulation and/or silicone sealer. Failure to do so will overload room and may result in comfort and energy cost problems. **In cold climates cold air entering around the unit can freeze and burst hot water or steam heat coils causing serious damage to the building and contents!**
- 4). Inspect the outdoor louver for free flow of air to the unit condenser coil. Airflow must not be obstructed by damaged, clogged, or misaligned louvers. Installations where non-standard louvers are employed must be approved by the factory in advance of replacement chassis installation. The chassis condenser coil must align with and contact the outdoor louver. If baffles are employed they must be of proper design, size, and location to prevent air recirculation! Measure the location of any air baffles in the sleeve and the chassis air inlet(s) to assure proper depth and side-to-side locations to prevent air recirculation within the sleeve. Failure to do so will degrade or inhibit unit performance and service life. Warranty will be voided if air recirculation is present.

Shrubs, plants, fences, or structures must not obstruct outdoor airflow. Building modifications or structures must not block or obstruct free airflow to the outdoor section of the unit. Units must not be positioned such that the discharge air of one unit blows to the inlet of an adjacent unit.

ELECTRICAL WIRING (See FIG. 2):

All electrical wiring must be in accordance with NEC and local codes.

- 1). Inspect the existing wiring for any deficiencies such as cut, frayed, or damaged wires. Repair or replace as necessary.
- 2). The nameplate on the new chassis indicates the operating voltage, phase, ampacity, maximum over-current protection, and minimum voltage. The power supply must be in accordance with these requirements! Use only **HACR type circuit breakers**. Inadequate wiring and/or improper electrical supply can cause a safety hazard and/or fire and will likely result in failure of the compressor and other electrical components and voids the warranty. The use of an extension cord is not allowed.

- 3). For installations where a new chassis is being used with existing control box, and blower/heat section the electrical plug from the control box will plug directly into the new chassis. If the installation uses new Adirondack-Air control box a new style electrical plug is provided with the new control box that plugs directly into the new chassis.

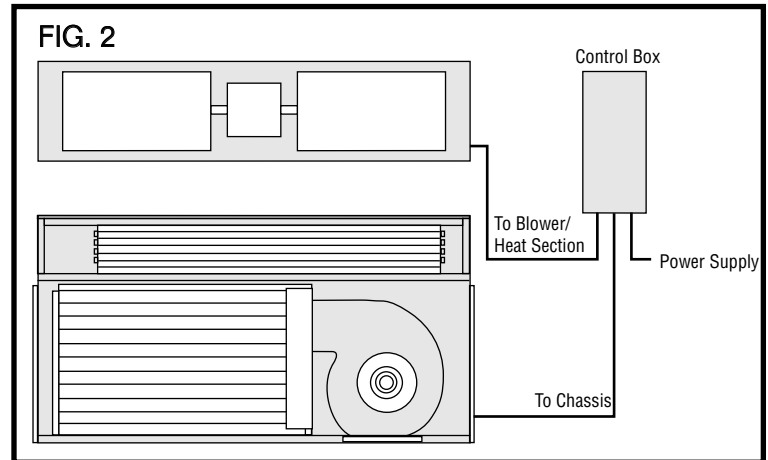

NOTE: Interconnect details apply to Adirondack-Aire supplied chassis and accessories. Refer to original Singer/McQuay diagrams if a new chassis is installed with old accessories

INSTALL THE NEW CHASSIS:

Refer to FIG. 2, which illustrates the chassis, blower/heat section and control box. Work with a helper to avoid personal injury or property damage, as the chassis may be too heavy to handle alone. FIG. 1, illustrates the individual sections that make up a complete installation.

- 1). Inspect the new chassis and spin the condenser side blower wheel by hand to make sure it has not been loosened or damaged in shipping. Adjust as necessary.
- 2). Confirm that wiring, piping, and heat coils are clear and allow for unobstructed chassis installation. Set the chassis condenser side edge on the wall box basepan and carefully slide the chassis into the wall sleeve. Confirm that the chassis is fully inserted into the sleeve.
- 3). Do a visual check to confirm a good weather seal between the chassis and the wall sleeve. Outdoor air infiltration around the wall sleeve and chassis must be sealed. Failure to do so will introduce outside air into the room and may result in comfort and energy cost problems. In cold climates cold air entering around the unit can freeze and burst hot water or steam heat coils causing serious damage to the building and contents! Any leakage must be sealed!
- 4). Check alignment and seal of the chassis with the blower/heat section. The chassis must properly align and seal with the grille to prevent performance, comfort, and reliability

problems. Add seals and/or realign the chassis or blower/ heat sections if necessary.

Furniture, curtains, or other obstructions that block airflow or cause air recirculation must be clear of free flow of air from the unit to the room. Carpet, furniture, or other obstructions must not block the return air at the bottom or front of the room cabinet (See FIG. 3).

5). Confirm that chassis is properly leveled side-to-side and front-to-back. Pour water into the chassis evaporator compartment and confirm that water does not overflow the unit's drain pan and is properly drained to the outside section. Correct any problems before proceeding.

6). Set unit control switch to 'OFF' position. Plug the electrical plug into the chassis receptacle.

7). Confirm air filter is properly installed in the chassis. Filter located in front of the chassis evaporator coil. **DO NOT OPERATE UNIT WITHOUT AIR FILTER IN PLACE!**

8). Install room cabinet front panel.

9). Turn power on at the breaker panel.

- Rotate the thermostat knob clockwise (towards blue) until the compressor and outdoor fan turn on. NOTE: The room temperature must be above 60 degrees F for the compressor to operate. After an initial stabilization period of 2-3 minutes the unit will produce cold air.
- Push the fan speed switch to the indicated 'HI' and 'LOW' positions. Confirm both fan speeds operate properly.
- Though some vibration and noise is normal the level should not be excessive or objectionable. If excess vibration and/or noise are experienced secure/repair/replace at the source until acceptable operation is achieved.
- After proper cooling and fan operation is confirmed slowly turn the thermostat knob counter clockwise (towards red) until a click is heard. The compressor and outdoor fan will shut off. Room side fan will continue to run or will also cycle off.

!CAUTION! DO NOT TURN THE THERMOSTAT KNOB BACK AND FORTH REPEATEDLY. This will stress the unit compressor and may cause permanent damage. Allow at least (3) minutes before restarting cooling operation.

- Push the control switch to the indicated 'OFF' position. All systems should shut down.

NOTE: When the unit is first started, high humidity conditions can cause condensation to form on the room cabinet grille and may overflow the condenser pan to the outside of the building. This is normal and temporary. Keep doors and windows closed and the unit will remove moisture from the room thereby eliminating excess condensate build-up.

HEATING OPERATION:

Adirondack-Aire PTAC units are offered with or without heat:

- A 'cooling only' unit will not have a 'HEAT' position.
- A heat pump will have reverse cycle heating with back-up electric heat built into the chassis.
- Adirondack-Aire replacement chassis with electric heating option will have the heating element built into the chassis.
- Replacement chassis for hot water or steam heat applications will have provision for a heat section control valve power connection. This is a (2) position connector, with wires attached, located at the left side of the chassis. A second (2) position connector, adjacent to the valve connection is also provided for connection to an optional 'aquastat'.
- Replacement chassis for hot water or steam heat applications will provide heating working with a heat coil. Some units will include an optional 'aquastat'. With this option the water supplied to the coil must be warm enough to provide heating, (at least 100° F). This is a function of the main building system and cannot be controlled at the unit. If the unit fails to provide heating check to see if the building is supplying heat to your unit.

HEATING OPERATION - COOLING UNITS WITH ELECTRIC HEAT

Electric heating element and controls are built into the chassis. Refer to FIG. 4 for typical control locations.

- Push the control switch to the indicated 'HEAT' position. For

FIG. 3

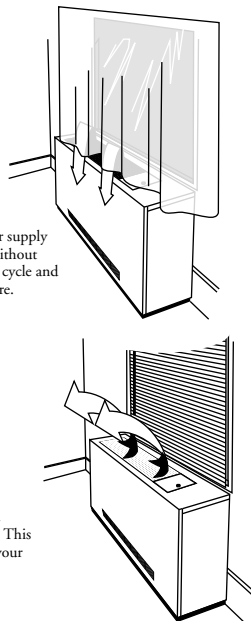

The position of curtains or drapes over supply air grille may cause air to recirculate without cooling the room. The unit will short cycle and may cause premature compressor failure.

Avoid restricted air flow, allowing cool air to circulate through out the room. This will ensure optimum performance of your Adirondack-Aire unit.

START-UP AND TEST RUN

Time spent to assure proper operation will eliminate callbacks and is time well spent to assure customer satisfaction.

COOLING OPERATION:

See typical control panel illustration FIG. 4

- Push the control switch to the indicated 'COOL' position. For most models the room side fan will turn on. For units with factory 'cycling fan' option the room side fan will not turn on until the thermostat calls for cooling.

most models the room side fan will turn on. For units with factory 'cycling fan' option the room side fan will not turn on until the thermostat calls for heating.

- Rotate the thermostat knob counter-clockwise (towards red) until an audible 'click' is heard. The compressor & condenser fan do not run during the heating cycle. After an initial warm-up period of a minute or so the unit will produce warm air. NOTE: Room temperature must be below 87° F to energize the heater.
- Push the fan speed switch to the indicated 'HI' and 'LOW' positions. Confirm both fan speeds operate properly.
- After proper heating and fan speed operation is confirmed slowly turn the thermostat knob clockwise (towards blue) until a click is heard. The heater will shut off. Room side fan will continue to run or will also cycle off.
- Push the control switch to the indicated 'OFF' position. All systems should shut down.

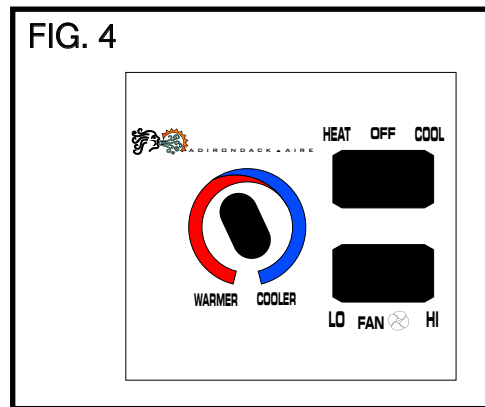

UNITS WITH HYDRONIC COILS: (STEAM OR HOT WATER)

This instruction is for installations where a new chassis is being used with an existing hydronic heat coil. If a new coil is being installed refer to separate coil installation instructions.

!CAUTION! CONFIRM THAT THE WALL SLEEVE AND CHASSIS SEALS DO NOT ALLOW AIR INFILTRATION. AIR LEAKAGE IN COLD CLIMATES CAN RESULT IN COIL FREEZE-UP AND BURST RESULTING IN PROPERTY DAMAGE!

The coil is typically located in one of three locations in the existing installation:

1. In the sub-base
2. Under the chassis.
3. Above the chassis.

HEATING OPERATION- WITH HYDRONIC HEAT COIL:

Refer to FIG. 4 for typical controls locations.

Replacement chassis for hot water or steam heat applications will have provision for a heat section control valve power connection. This is a (2) position connector, with wires attached, located at the left side of the chassis. If the chassis connector and valve connector is not compatible the connector can be cut off and the wires spliced. A second, (2) position connector, adjacent to the valve connection is also provided for connection of an optional 'aquastat'.

Refer to FIG. 4 for typical controls locations

- Confirm that the motorized valve, (if used), is plugged into the chassis connector. **!CAUTION! CONFIRM THAT THE VALVE VOLTAGE AND THE UNIT VOLTAGE SUPPLIED AT THE VALVE CONNECTOR ARE COMPATIBLE. DO NOT PLUG THE VALVE INTO THE CONNECTOR WITHOUT CHECKING FIRST!**
- Confirm that the optional 'aquastat', (if used), is plugged into the chassis connector.
- Push the control switch to the indicated 'HEAT' position. For most models the room side fan will turn on. For units with factory 'cycling fan' option the room side fan will not turn on until the thermostat calls for heating. If an optional 'aquastat' is used the fan will not turn on unless hot water or steam is available at the heat coil.
- Rotate the thermostat knob counter-clockwise (towards red) until an audible 'click' is heard. The compressor and condenser fan do not run during the heating cycle. After an initial warm-up period of a minute or so the unit will produce warm air. NOTE: Room temperature must be below 87° F to energize the heat.
- Push the fan speed switch to the indicated 'HI' and 'LOW' positions. Confirm both fan speeds operate properly.
- After proper heating and fan speed operation is confirmed slowly turn the thermostat knob clockwise (towards blue) until a click is heard. The heat will shut off. Room side fan will continue to run or will also cycle off.
- Push the control switch to the indicated 'OFF' position. All systems should shut down.

FRESH AIR DAMPER:

The 'EK' incorporates the use of a motorized damper door. Operation is automatic: The ventilation damper constantly supplies the room with **fresh air**. This damper is always open for introduction of fresh air unless it is closed by the manual override switch, See FIG. 5.

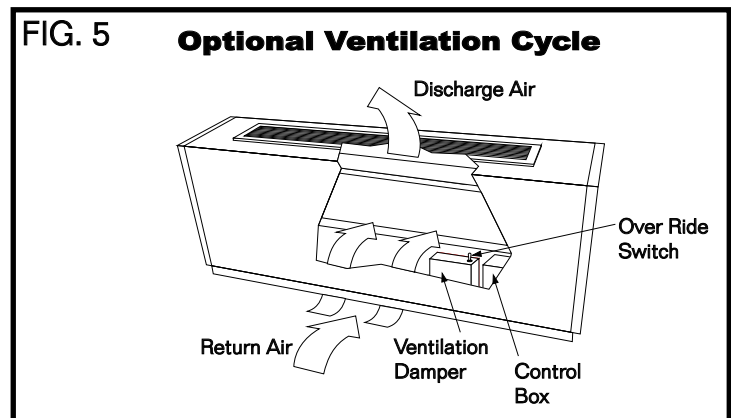

HIGH PRESSURE SWITCH- The Adirondack-Aire 'EK' chassis includes a manual Reset High Pressure Switch. This switch will shut down the compressor and condenser fan should system pressure rise to excessive levels. Chassis removal is required to reset the switch. Be sure to trouble shoot and remedy the source of the excessive pressure before leaving the chassis.

EVAPORATOR FREEZE STAT- If for any reason the evaporator coil starts to frost the unit will shut down until the coil frost dissipates. If frosting occurs repeatedly troubleshooting is necessary to prevent unit damage.

OVERRIDE SWITCH- The damper override switch (located behind the room cabinet front panel) can be set in the 'normal' or 'off' position. The switch position should be set according to building requirements.

FINAL INSPECTION:

Do a final visual inspection of the entire installation and confirm the following:

- The unit is clean and all tools and construction debris has been picked up.
- Room furnishings, carpets, and the like have been replaced in their original position.
- All controls and protective devices function properly.
- The unit air filter is properly installed.
- The unit delivering the proper amount of conditioned air.
- Unit operation is acceptably quiet and free of vibration.
- Nothing is obstructing the supply air and return air to and from the unit.

MAINTENANCE:

Unit performance is maintained at optimum levels by implementing the following preventive measures:

●FILTER MAINTENANCE

Adirondack-Aire PTAC units are furnished with a permanent, washable, electrostatic type air filters. **The unit must not be operated without this filter installed. Filter should be inspected at least every three months, and cleaned when dirty. Unit operation becomes very inefficient** and system components are stressed with dirty filters. Unit warranty is void if filters are not maintained properly.

●CONDENSATE DRAINS

Condensate drains can pick up lint and dirt, especially with dirty filters. Inspect, and if dirty, clean the condensate drain pan twice a year to avoid the possibility of overflow.

●CHECK WIRING

Annually or as a part of a service call check the tightness of the various wiring connections within the control panel.

●FAN MOTORS

The direct-drive blower and fan motors have permanently sealed, lubricated bearings, and do not require periodic oiling. Adding a few drops of 20W non-detergent oil through the oil ports (if equipped) twice a year may however extend life of the bearings. **DO NOT** over oil.

●MICROBIAL GROWTH

Microbial growth can occur in air conditioners anywhere in the air stream where moisture exists. ASHRAE standards 62-89 recommends that these surfaces be inspected and cleaned to limit contamination. This typically includes surfaces beginning at the finned coil, drain pan, insulation, and fan/blowers

●INSPECTING AND CLEANING FINNED

EVAPORATOR AND CONDENSER COILS

Coils become externally fouled as a result of normal operation.

Dirt on the surface of the coil reduces its ability to transfer heat that can result in comfort problems, increased resistance to airflow and result in increased operating energy costs. If the dirt on the surface of the coil becomes wet, such as commonly occurs with cooling coils, microbial growth can result which may cause unpleasant odors and serious health related indoor air quality problems. Coils should be inspected at least every six months or more often as necessary. The frequency of the required inspection/cleaning is dependent on the operating hours of the system, filter maintenance and efficiency, and dirt build-up. The following is the suggested method of cleaning coils:

- 1). Disconnect all electrical power to the unit.
- 2). Wear the appropriate personal protective equipment.
- 3). Gain access to the coil section of the unit (both sides).
- 4). Using a soft brush, remove loose debris from both sides of the coil.
- 5). Mix a high quality coil cleaning detergent with water according to the manufacturers instructions. If the detergent is strongly alkaline after mixing (8.5 pH or higher), it must contain a corrosion inhibitor. Carefully follow the cleaning solution manufacturers instructions regarding the use of the product.
- 6). Placed the mixed solution in a pump sprayer or high pressure sprayer. If a high pressure sprayer is used, note the following:
 - A. Maintain a minimum nozzle spray angle of 15 degrees.
 - B. Spray perpendicular to the coil face.
 - C. Protect other areas of the air handler and internal controls from contact with moisture or the cleaning solution.
 - D. Keep the nozzle at least 6 inches from the coil.
 - E. Do NOT exceed 600psi.
- 7). Spray the leaving air side of the coil first, then the entering air side. Use a block-off to prevent spray from going through the coil and into a dry section of the unit and/or system ductwork. Carefully follow the cleaning solution manufacturers usage instructions.
- 8). Thoroughly rinse both sides of the coil and the drain pan with cool, clean water.
- 9). Repeat steps 7 and 8 as necessary.
- 10). Using a fin brush straighten any coil fins that may have been damaged during the cleaning process.
- 11). Confirm that the drain line remains open following the cleaning process.
- 12). Replace all panels and parts.
- 13). Allow the unit to dry before putting unit back in service. Restore electrical power to the unit.
- 14). Be careful that the contaminated material does not come into contact with other areas of the unit or building. Properly dispose of all contaminated materials and used cleaning solution. Store unused solutions according to manufacturer's directions.

OPERATING INSTRUCTIONS

Operation of the unit is automatic and will provide cooling and heating (optional) depending on the settings of the Cool Heat selector switch, Fan 'HI' 'LO' switch, and Thermostat.

COOLING OPERATION:

IMPORTANT COOLING INFORMATION!

- When the unit is first started, high humidity conditions can cause condensation to form on the room cabinet grille and may overflow the condenser pan to the outside of the building. This is normal and temporary. Keep doors and windows closed and the unit will remove moisture from the room thereby eliminating excess condensate build-up.
- Wait at least 3 minutes after turning the air conditioner off before trying to restart it. This gives the unit the time needed to stabilize before restarting. Failure to do so may cause unit damage and failure.
- A properly installed and sized unit will not cycle more than 10 times per hour. If you notice more frequent starts call your service contractor.
- For energy conservation reasons you may want to set your thermostat at a higher temperature when you are away. Do not raise the temperature setting by more than 5 degrees. Changing the temperature by more than 5 degrees or shutting the unit 'off' can actually cost more than leaving the setting at a constant temperature.

INSTRUCTIONS

(See FIG. 5)

- Open the cabinet control door. Locate the "COOL", 'OFF', 'HEAT' and the 'FAN' 'HI' 'LO' switches. Push the switch on the unit control panel to the 'COOL' position. For most models the room side fan will turn on. For units with factory 'cycling fan' option the room side fan will not turn on until the thermostat calls for cooling.
- Select either FAN 'HI' or 'LO' as desired. The 'HI' setting will provide maximum cooling and is recommended to cool a room at maximum unit capacity. Select 'LOW' once the room is at the desired temperature and the unit has begun to cycle on-off to maintain the desired temperature.
- Set the desired temperature you want to maintain by moving the thermostat dial to the 'WARMER' or 'COOLER' position. If the room is warmer than the setting, the unit will turn on and begin to blow cool air after a few minutes. Note that a warm humid room or building may take several hours of continuous operation to cool to the thermostat set point the first time. Once the set temperature is reached the unit will cycle on and off normally.
- CAUTION! DO NOT TURN THE THERMOSTAT KNOB BACK AND FORTH REPEATEDLY.** This will stress the unit compressor and may cause permanent damage. Allow at least (3) minutes before restarting cooling operation.
- Pushing the control switch to the indicated 'OFF' position will shut all systems down.

HEATING OPERATION:

IMPORTANT HEATING INFORMATION!

- A 'cooling only' unit will not have a 'HEAT' position.
- Replacement chassis with electric heating option will have the heating element built into the chassis.
- A heat pump will have reverse cycle heating with back-up electric heat built into the chassis.
- Replacement chassis for hot water or steam heat applications will provide heating working with a heat coil. Some units will include an optional 'aquastat'. With this option the water supplied to the coil must be warm enough to provide heating, (at least 100° F). This is a function of the main building system and cannot be controlled at the unit. If the unit fails to provide heating check to see if the building is supplying heat to your unit.
- (See FIG. 5) Open the cabinet control door. Locate the "COOL", 'OFF', 'HEAT' and the 'FAN' 'HI' 'LO' push button switches. Push the switch on the unit control panel to the 'HEAT' position. For most models the room side fan will turn on. For units with factory 'cycling fan' and/or aquastat option the room side fan will not turn on until the thermostat calls for heating and heat is available at the heat coil.
- Setting the switch on the control panel to the 'Heat' position and setting the desired temperature activates heating operation. When heating, the 'LO' fan position is recommended. Adjust the temperature set point above room temperature warm air should blow from the cabinet supply air grille. The unit will activate the heat automatically to maintain the set room temperature. As in cooling turn the thermostat knob to 'WARMER' or 'COOLER' as desired
- Pushing the control switch to the indicated 'OFF' position will shut all systems down.

•FRESH AIR DAMPER (OPTIONAL):

The motorized fresh air damper introduces outside air into the room. Units equipped with this option have a control switch located behind the room cabinet front panel that opens and closes the door. Select the desired position and operation is automatic.

BEFORE CALLING FOR FACTORY ASSISTANCE:

A call to the factory is sometimes necessary for technical support or service/troubleshooting. We are happy to help! Before calling please gather and record the following information so that we are best able to help.

Cold Point Corp.
7500 Cold Point Dr.
Rome, NY 13440
Phone:315.339.2331
Fax: 315.339.2358
e-mail: info@coldpointcorp.com

- ___ Unit Model No
- ___ Unit Serial number
- ___ Name of Job or Installation
- ___ Your Name
- ___ Your Company's Name
- ___ Your Company's Address
- ___ Your Company's Phone, Fax, and e-mail
- ___ Room Temperature -DB/WB

- ___ Outdoor Temperature- DB/ WB
- ___ Suction Pressure
- ___ Discharge pressure
- ___ Suction Superheat
- ___ Voltage @ contactor
- ___ Amp Reading (clamp-on)
- ___ Your Diagnosis or Question

RECORDS:

Date of Installation _____

Model number _____

Serial number _____

Installing Contractor _____

Address _____

Phone No. _____

SERVICE/MAINTENANCE:

Date	Work Performed	BY
_____	_____	_____
_____	_____	_____
_____	_____	_____
_____	_____	_____
_____	_____	_____
_____	_____	_____

Notes: _____

